

Model Number:

MMP BL86-425G-48V GRA81-059

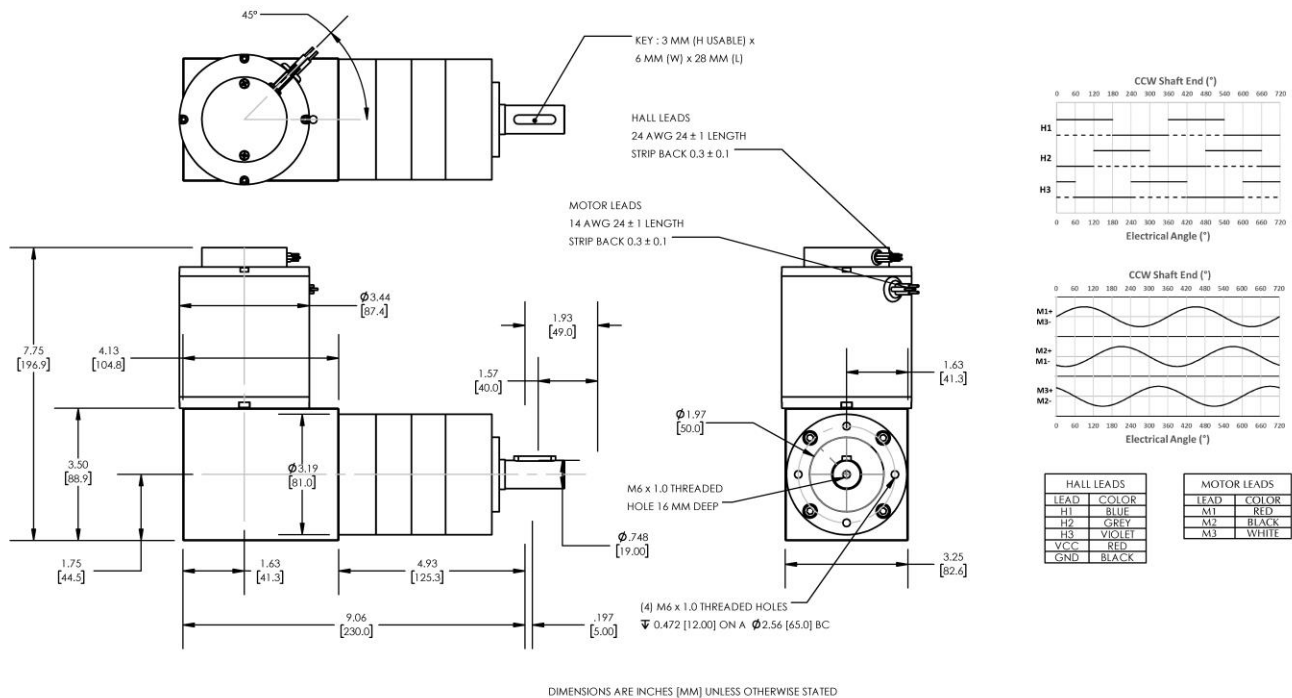

PLANETARY GEARMOTOR OUTPUT PARAMETERS:	VALUE	UNITS	TOLERANCE
Gearhead Ratio (exact)	58.85 : 1		
Gearhead Shaft Output Speed (at full-load)	60	RPM	MAX
Gearmotor Rated Continuous Torque	373	In-Lbs	MAX
Gearmotor Rated Peak Torque	908++	In-Lbs	----
Gearhead Standard Backlash	36	Arc Minutes	MAX
Gearhead Efficiency	70%	----	----
Output Shaft Radial Load Capacity	225	Lbs	MAX
Output Shaft Axial Load Capacity	45	Lbs	MAX
Gearmotor Total Weight	15	Lbs	MAX

++ All Peak Torque values are dependent upon duty. Contact our sales office for details.

DC MOTOR PERFORMANCE PARAMETERS:	VALUE	UNITS	TOLERANCE
Rated DC Voltage	48	DC VOLTS	----
Rated Continuous Current	11.8	AMPERES	----
No-Load Speed	4948	RPM	MAX
Rated Speed	3505	RPM	+/- 15%
Rated Continuous Power Out	377	WATTS	+/- 15%
Rated Continuous Torque	145	OZ-IN	----
Peak Torque (motor only)	353	OZ-IN	----
No-Load Current	0.69	AMPERES	MAX
Back EMF Constant (Ke)	9.7	V/KRPM	+/- 10%
Torque Constant (Kt)	13.1	OZ-IN/AMP	+/- 10%
DC Armature Resistance	1.19	OHMS	+/- 15%
Armature Inductance	1.07	mH	+/- 15%
Armature temperature	155	DEG. C	MAX

NOTES:

- ENCODER & BRAKE OPTIONS AVAILABLE – [FOLLOW THIS LINK FOR DETAILS](#)
- NEMA MOUNTING FLANGE OPTION AVAILABLE – [FOLLOW THIS LINK FOR DETAILS](#)

MIDWEST MOTION PRODUCTS, INC

DESIGN, MANUFACTURING & DISTRIBUTION - MOTION CONTROL EQUIPMENT

www.midwestmotion.com

email: sales@midwestmotion.com